

DATI TECNICI

S Y N C R O C N

TECHNICAL DETAILS

DIMENSIONI MASSIME DEL PANNELLO	mm	3000X900	WORKING MAX DIMENSIONS
DIMENSIONI MINIME DEL PANNELLO	mm	300X110	WORKING MIN. DIMENSIONS
SPESSORE MIN/MAX LAVORABILE	mm	12/45	MIN./MAX PANEL THICKNESS
VELOCITA' MASSIMA PROGRAMMABILE:	Asse X1	100 m/min	AXIS X1
	Asse X2	55 m/min	AXIS X2
	Asse X3	15 m/min	AXIS X3
	Asse Y	45 m/min	AXIS Y
	Asse Z	10 m/min	AXIS Z
TOLLERANZA SU POSIZIONAMENTO ASSI	mm	+/- 0,1	TOLERANCE ON AXES POSITIONING
POTENZA MOTORE MANDRINI		2 HP - 3200 r.p.m.	SPINDLE MOTOR POWER
TOTALE MANDRINI INDIPENDENTI	N°	9+9 18+17	INDEPENDENT VERTICAL SPINDLES
TOT. MANDRINI DISPOSTI IN COORDINATA " X "	N°	9 17	TOTAL OF SPINDLES SET IN " X " COORDINATE
TOT. MANDRINI DISPOSTI IN COORDINATA " Y "	N°	9 18	TOTAL OF SPINDLES SET IN " Y " COORDINATE
ATTACCO PORTAUTENSILE	mm	10	TOOL HOLDER CHUCK
DIAMETRO MASSIMO UTENSILE	mm	35	MAXIMUM USEFUL TOOL DIAMETER
ASSI CONTROLLATI	N°	5	CONTROLLED AXES
UNITA' INVERTER		5,5 KW	INVERTER
MOTORE LAMA F 125 MM.	HP	1,8	SAW MOTOR F 125 MM.
MASSIMA POTENZA RICHIESTA	KW	10	MAXIMUM INSTALLED POWER
PRESSIONE DI ESERCIZIO	bar	6-8	OPERATING PRESSURE
CONSUMO D'ARIA COMPRESSA	NI/Min	6 X CICLO DI LAVORO	COMPRESSED AIR CONSUMPTION
VELOCITA' ARIA ASPIRANTE	m/s	30	DUST EXTRACTION SPEED
CONSUMO ASPIRAZIONE TRUCCIOLO	m ³	3393	DUST EXTRACTION POWER
PESO MACCHINA	Kg	2500	WEIGHT OF MACHINE
PESO CENTRALINA	Kg	350	WEIGHT OF ELECTRIC CABINET
PESO RULLIERA	Kg	450	ROLLER CONVEYOR WEIGHT
DIMENSIONI DI INGOMBRO MACCHINA	mm	3500X1500X1500	MACHINE OVERALL DIMENSION
DIMENSIONI DI INGOMBRO CENTRALINA	mm	1450X600X1900	ELECTRIC CABINET OVERALL DIMENSION
DIMENSIONI DI INGOMBRO RULLIERA	mm	3000X900X900	ROLLER CONVEYOR OVERALL DIMENSION
PRESA ALLACCIAMENTO RETE ARIA	mm	17X26	COMPRESSED AIR CONNECTION

Configurazione Syncro 18/Cn
Syncro Configuration 18/Cn

Configurazione Syncro 36/Cn
Syncro Configuration 36/Cn

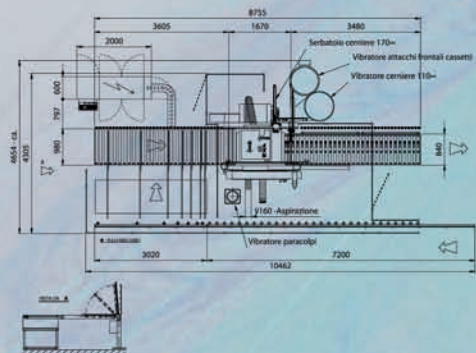
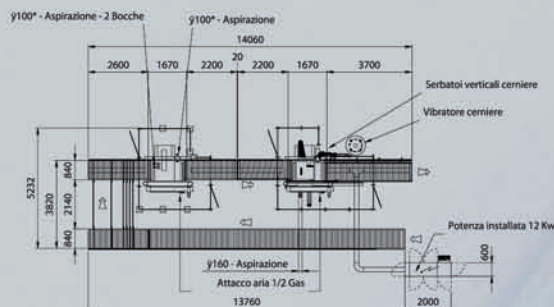
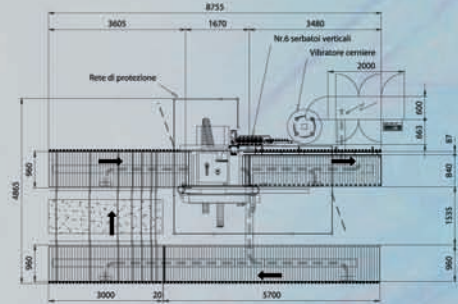
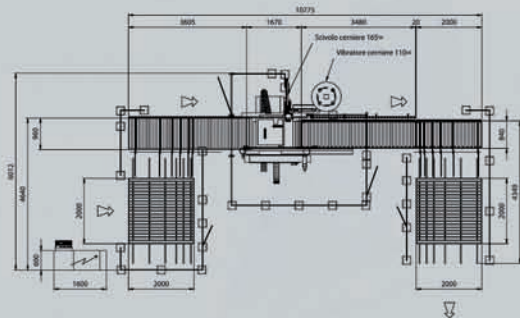

Alberti Engineering si riserva di apportare modifiche senza obbligo di preavviso.
Alberti Engineering has the right to do modification without any notice.